

- OFFICE
- RETAIL
- SERVICE / CORE/ OPERATIONS
- ROOFSCAPE / TERRACE
- GREEN ROOF
- OPEN TO BELOW
- ROOF BELOW

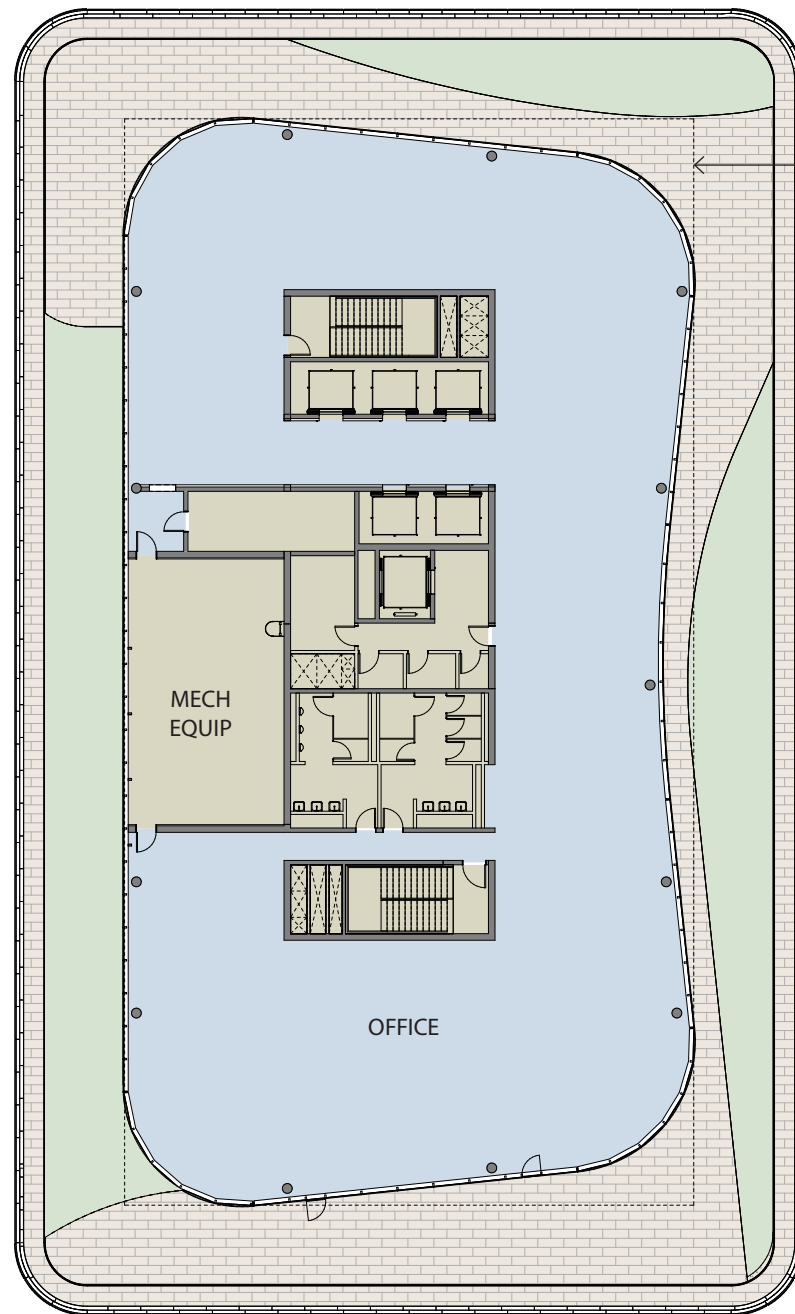

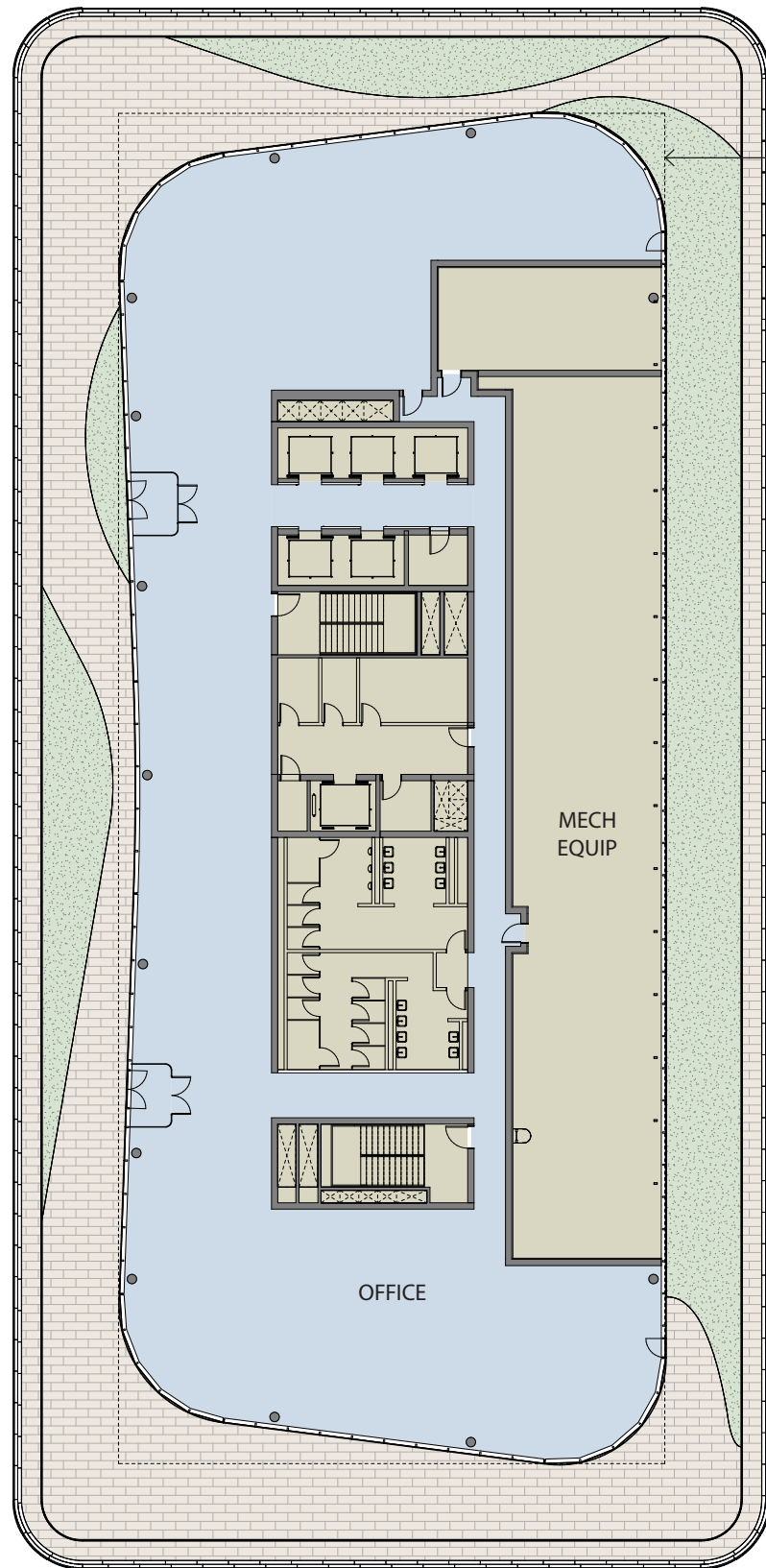

- OFFICE
- RETAIL
- SERVICE / CORE/ OPERATIONS
- ROOFSCAPE / TERRACE
- GREEN ROOF
- OPEN TO BELOW
- ROOF BELOW



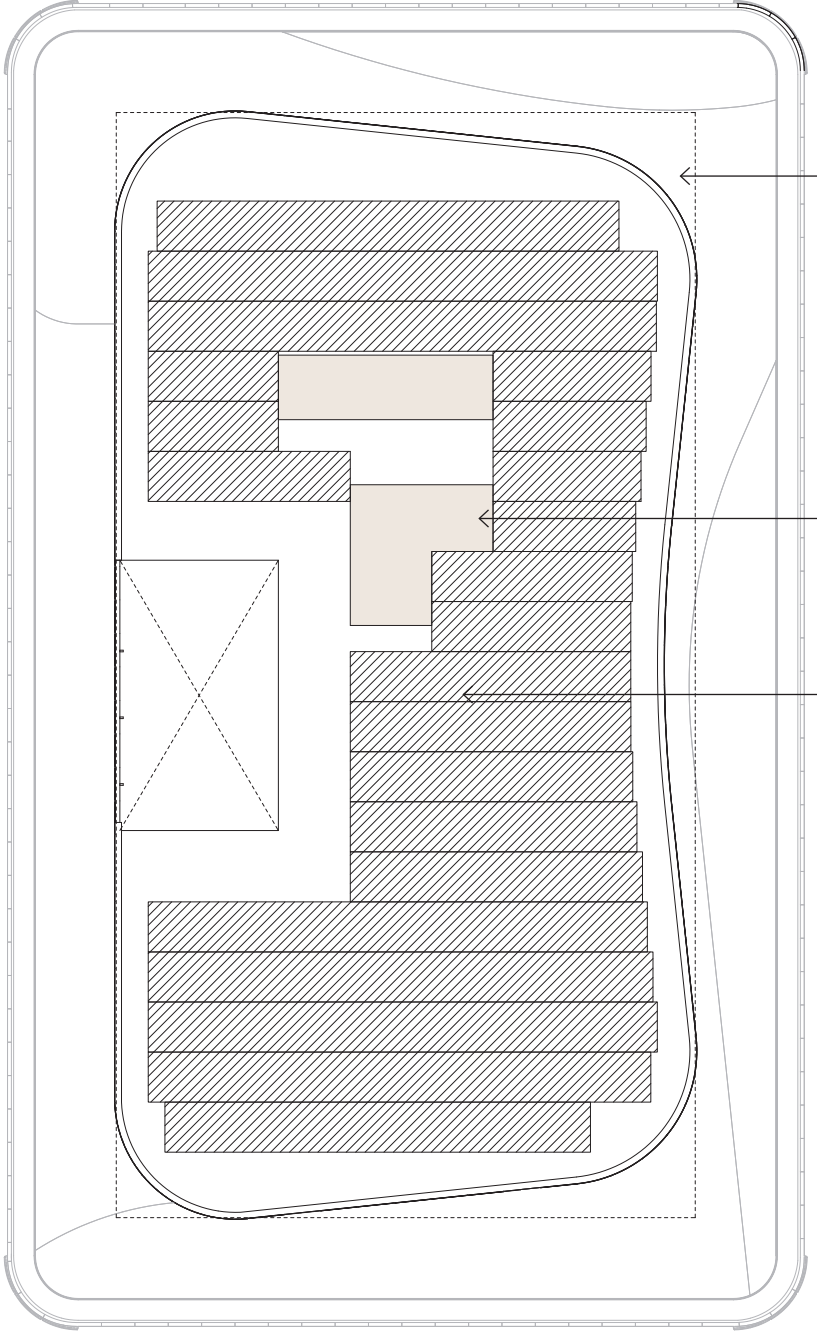
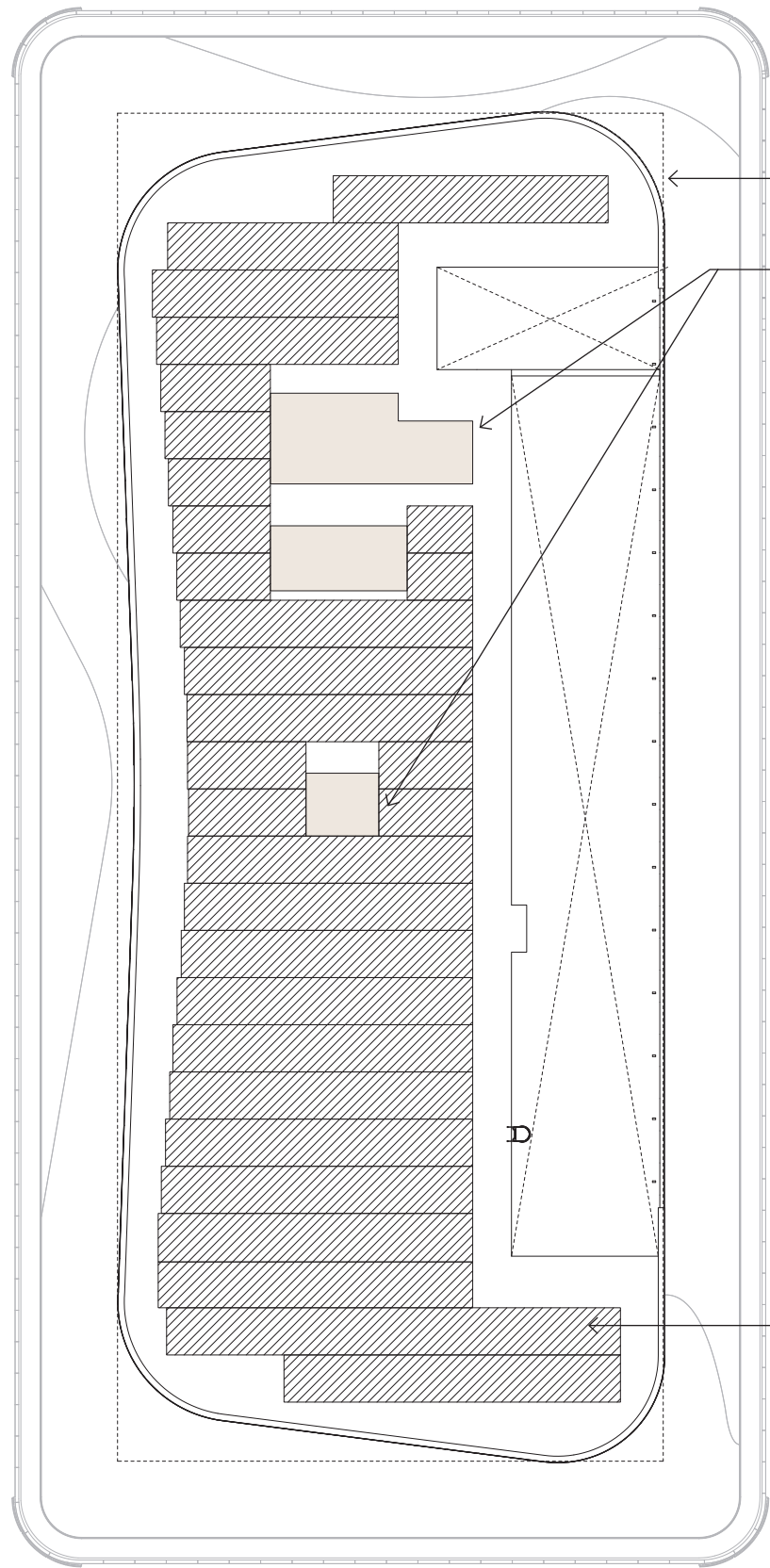

1:1 SET BACK REQUIREMENT (TO 16'-0")

ELEVATOR HOISTWAY (TO 20'-0")

SOLAR PV PANELS*

* SOLAR PV PANEL LAYOUT TO BE DEVELOPED
FLOOR AREA AVAILABLE FOR SOLAR PV INSTALLATION
P6 - 11,000 SF / P7 - 10,000 SF APPROX



- OFFICE
- RETAIL
- SERVICE / CORE/ OPERATIONS
- ROOFSCAPE / TERRACE
- GREEN ROOF
- OPEN TO BELOW
- ROOF BELOW

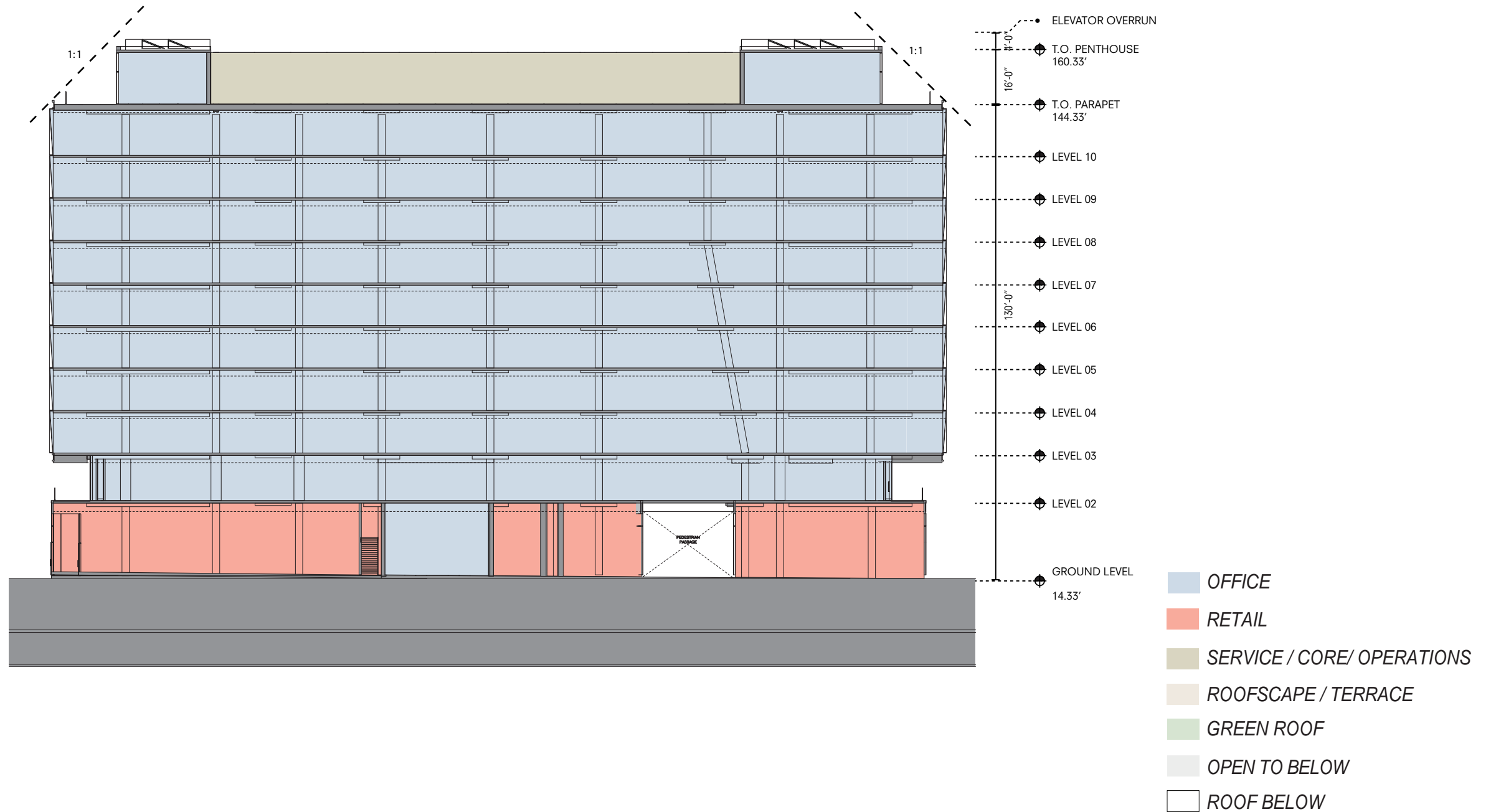
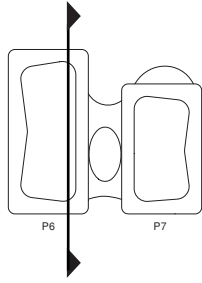

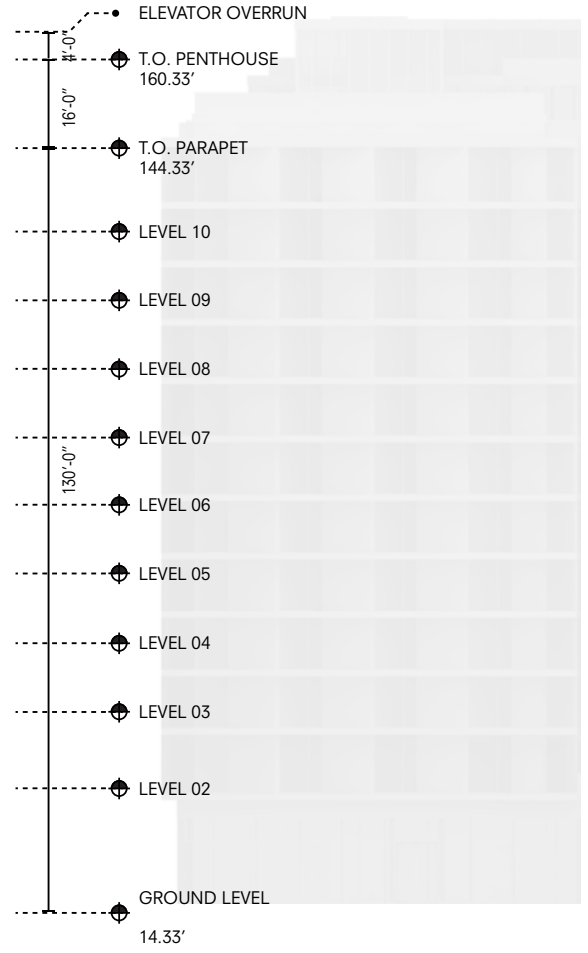
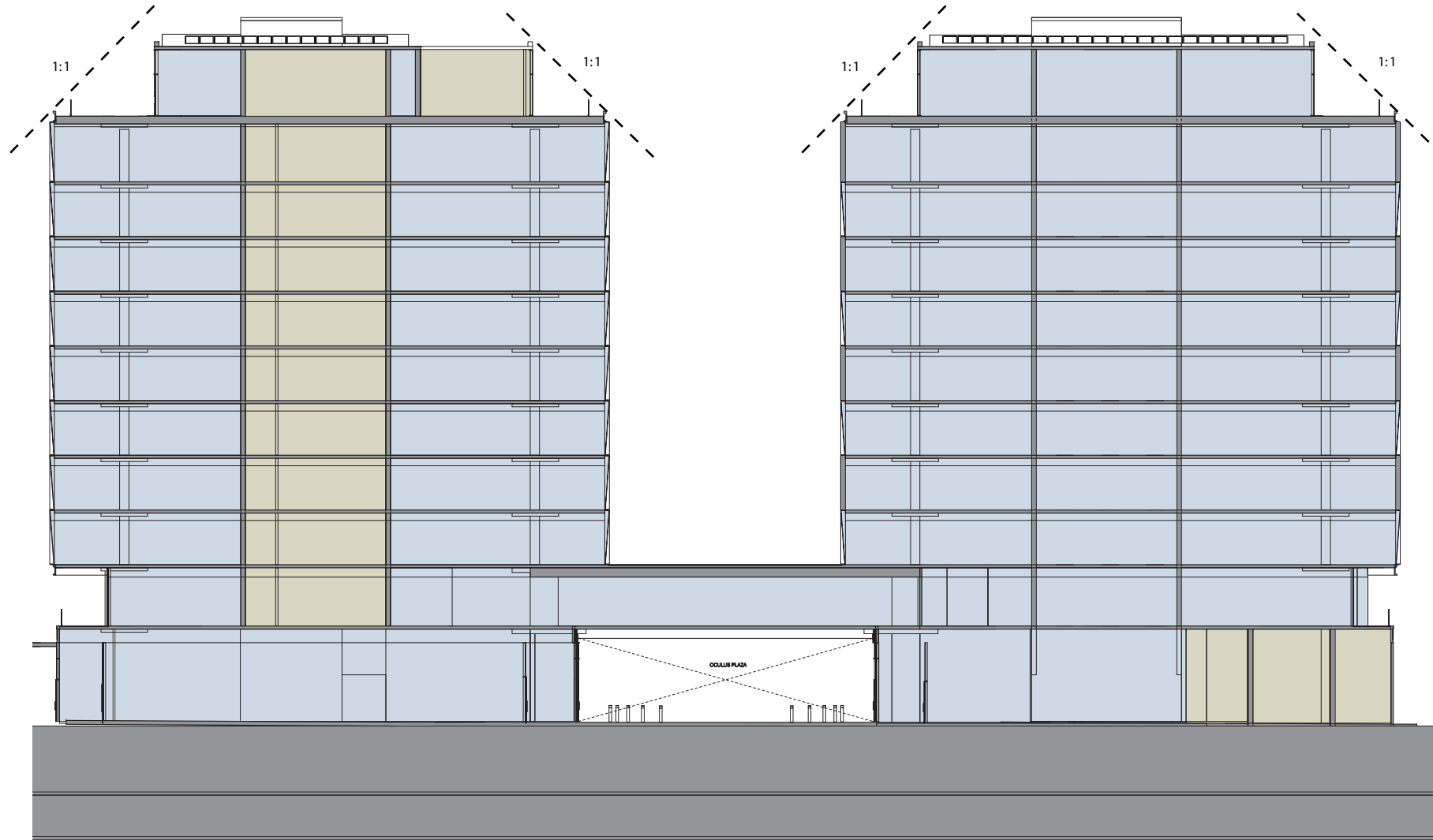
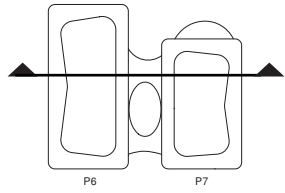

- OFFICE
- RETAIL
- SERVICE / CORE/ OPERATIONS
- ROOFSCAPE / TERRACE
- GREEN ROOF
- OPEN TO BELOW
- ROOF BELOW







BRONZE FINISH

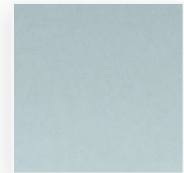

SEMI REFLECTIVE GLASS



LUSTER FINISH METAL

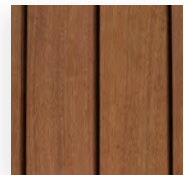

WOOD FINISH SOFFIT

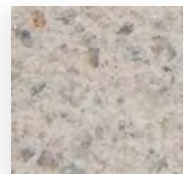

CONCRETE PAVER



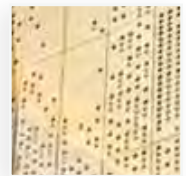

ALUMINUM

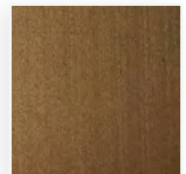

BRONZE FINISH

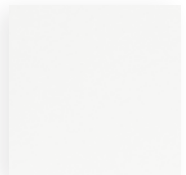

LOW REFLECTIVE GLASS

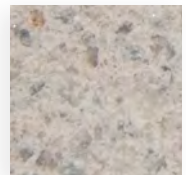

CONCRETE PAVER



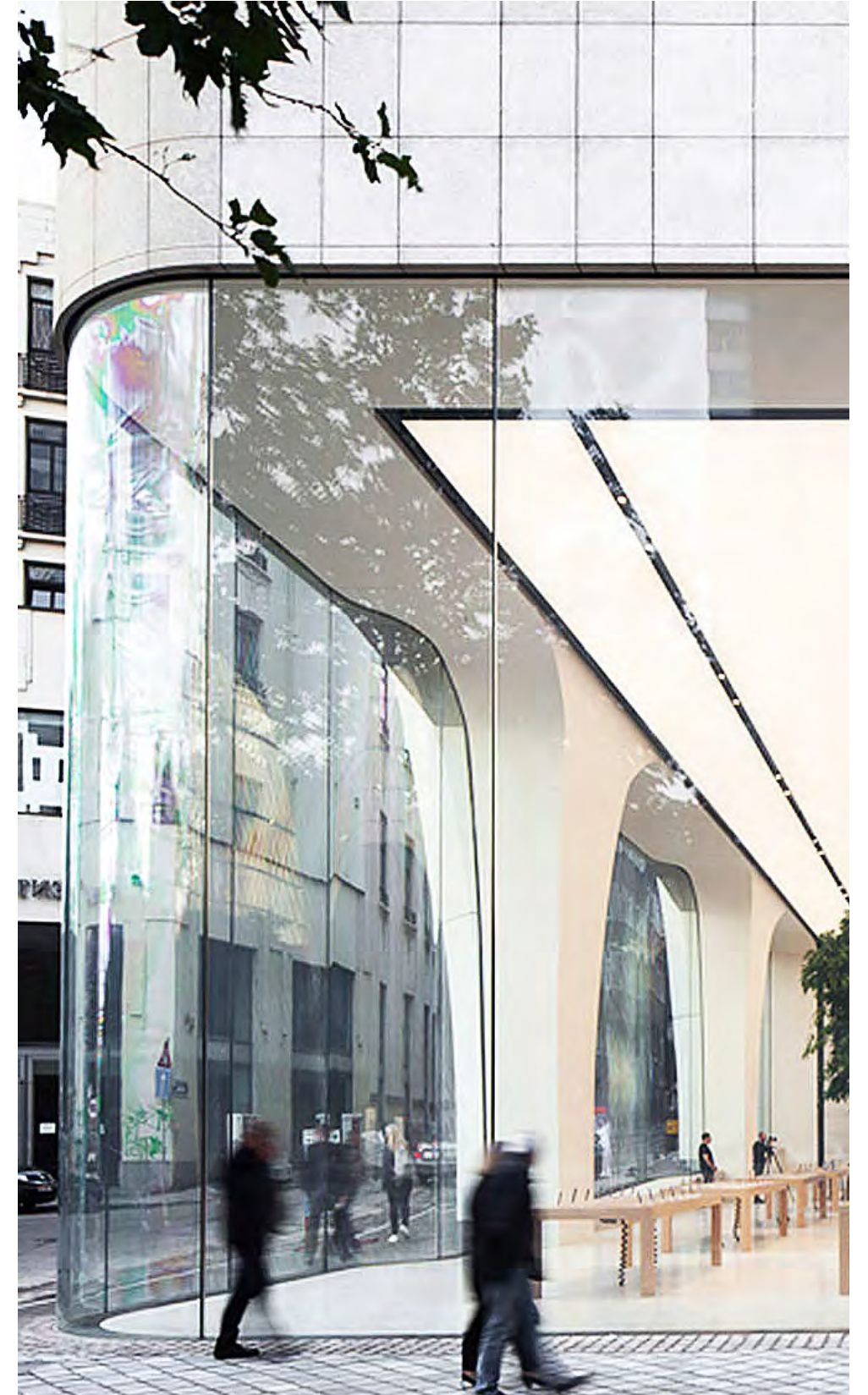
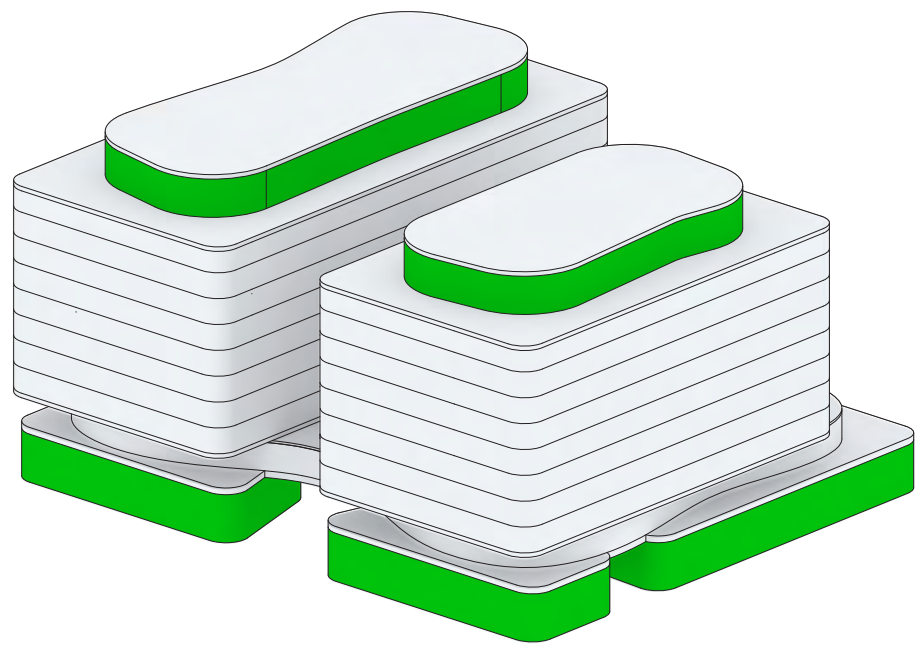

PRECEDENTS

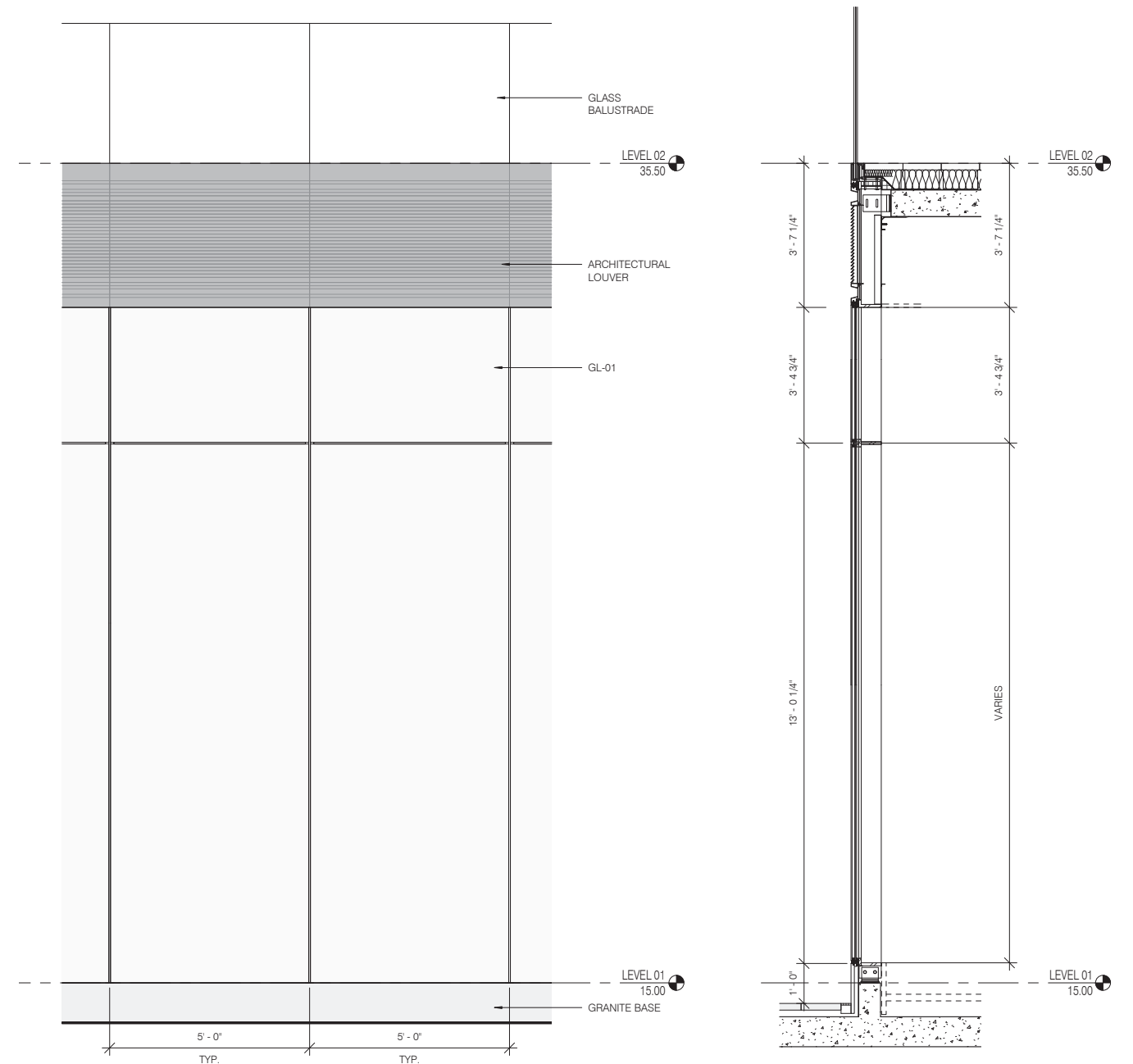

ELEVATION

SECTION

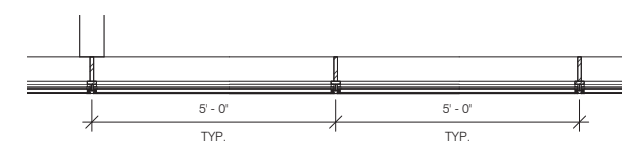

PLAN

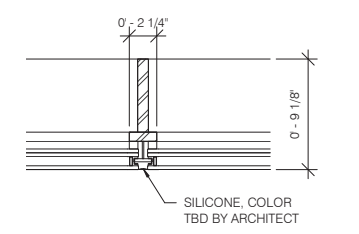

ENLARGED PLAN

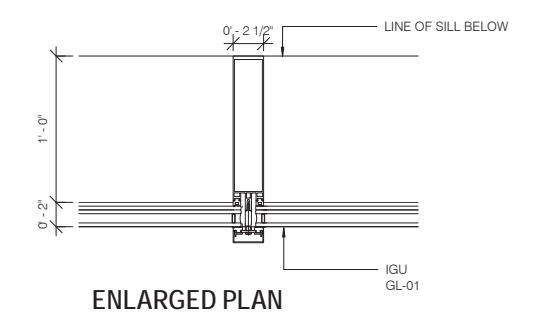
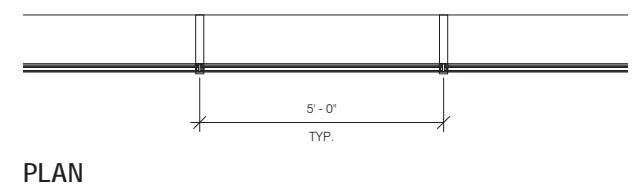
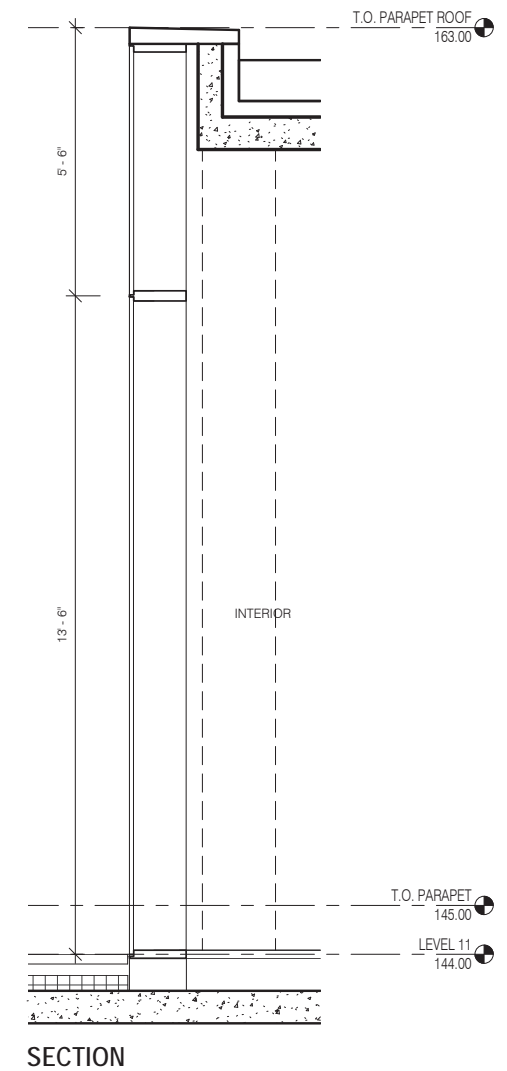
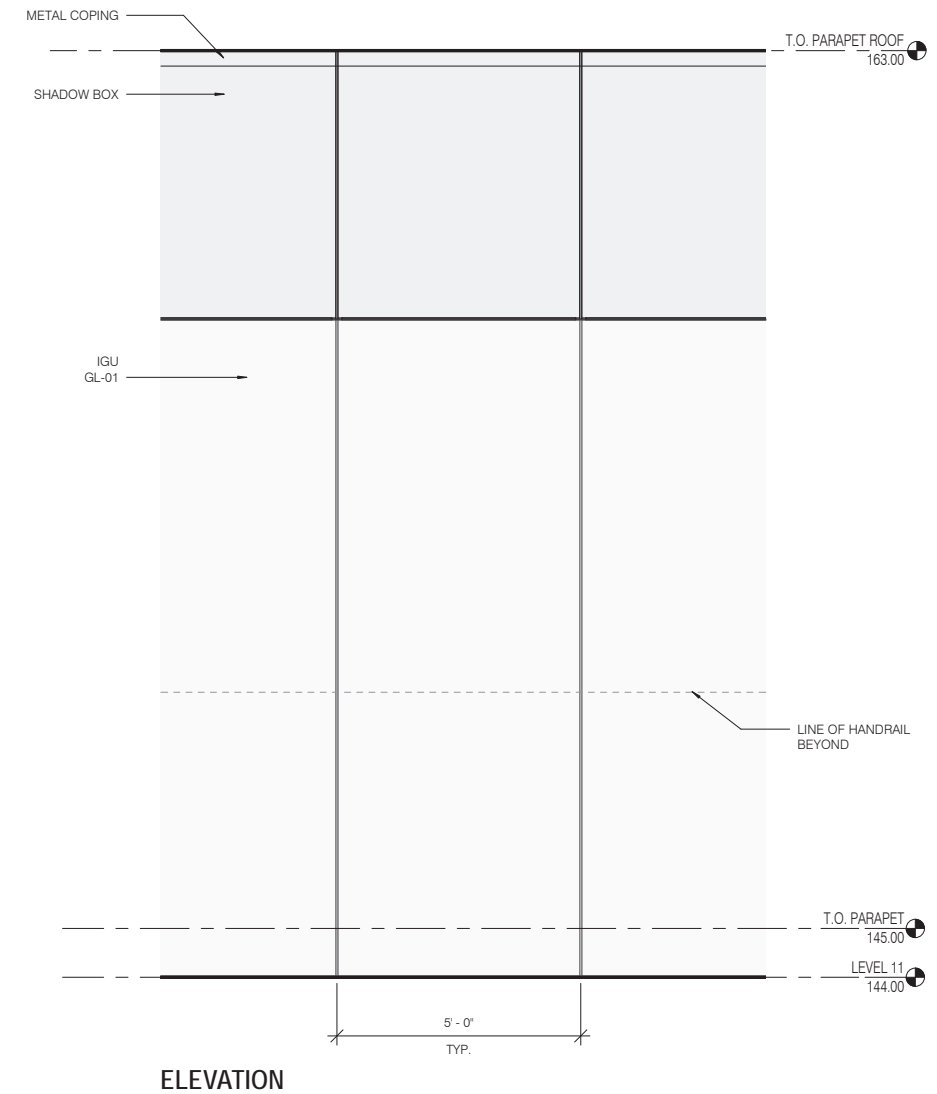

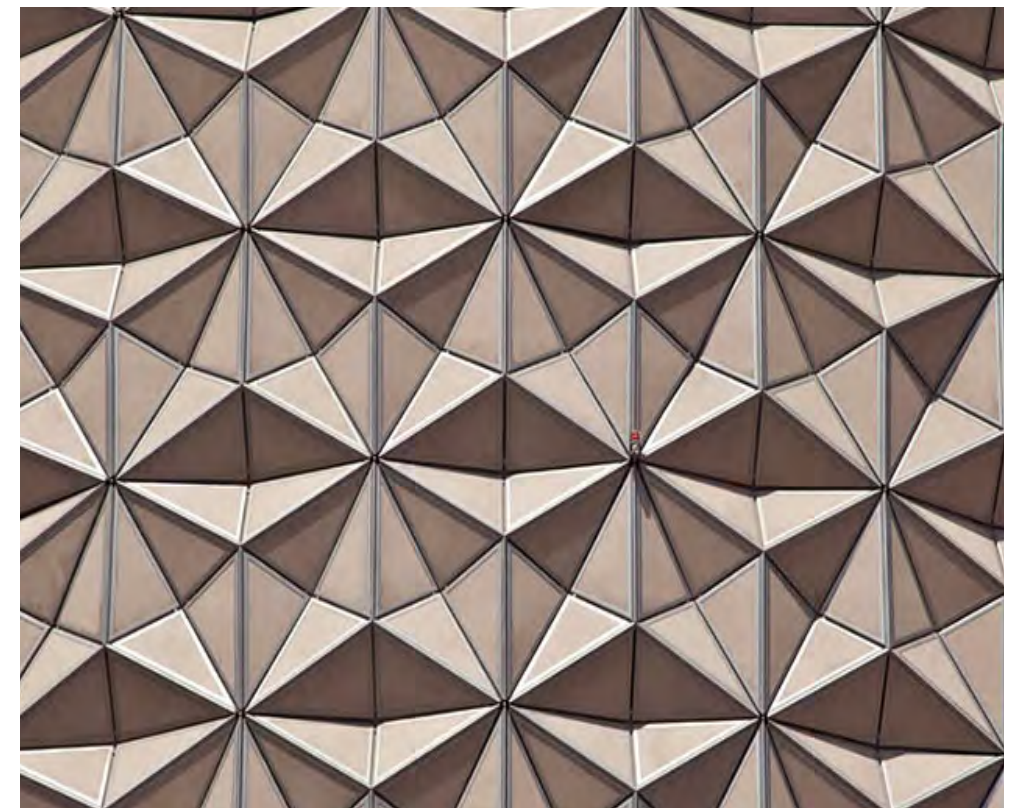
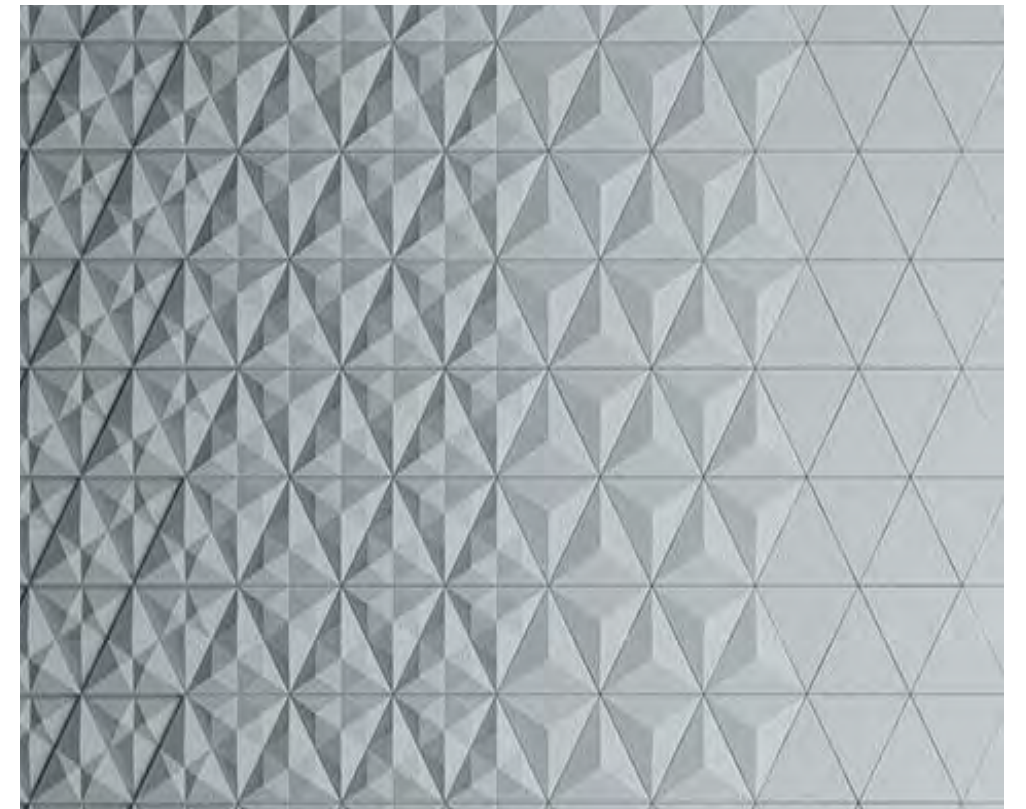
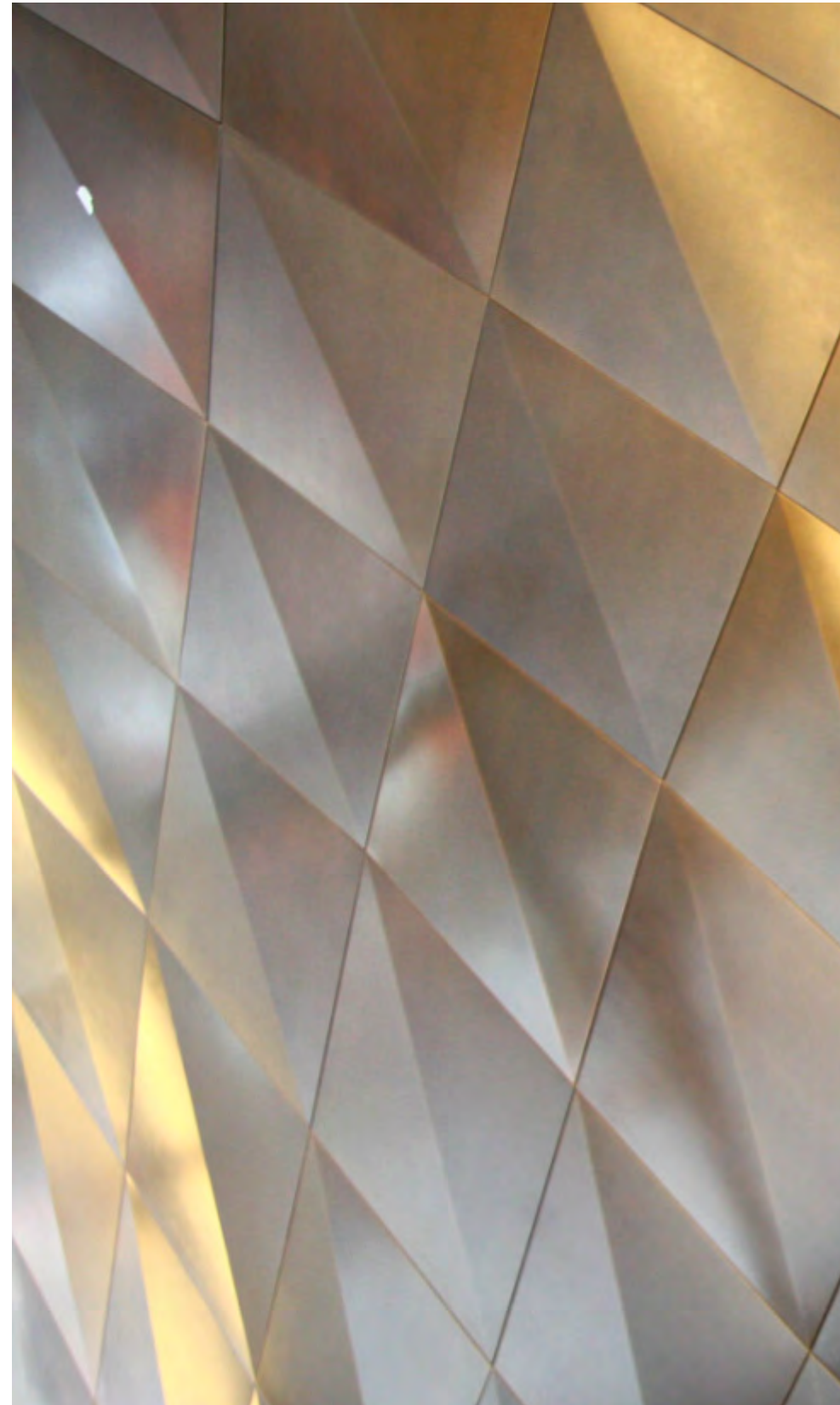
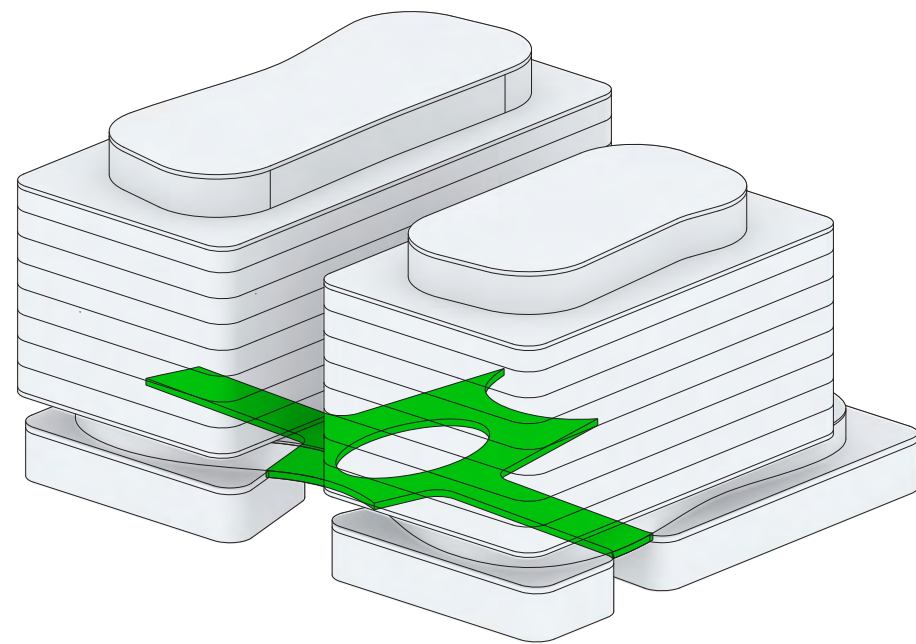

PRECEDENTS

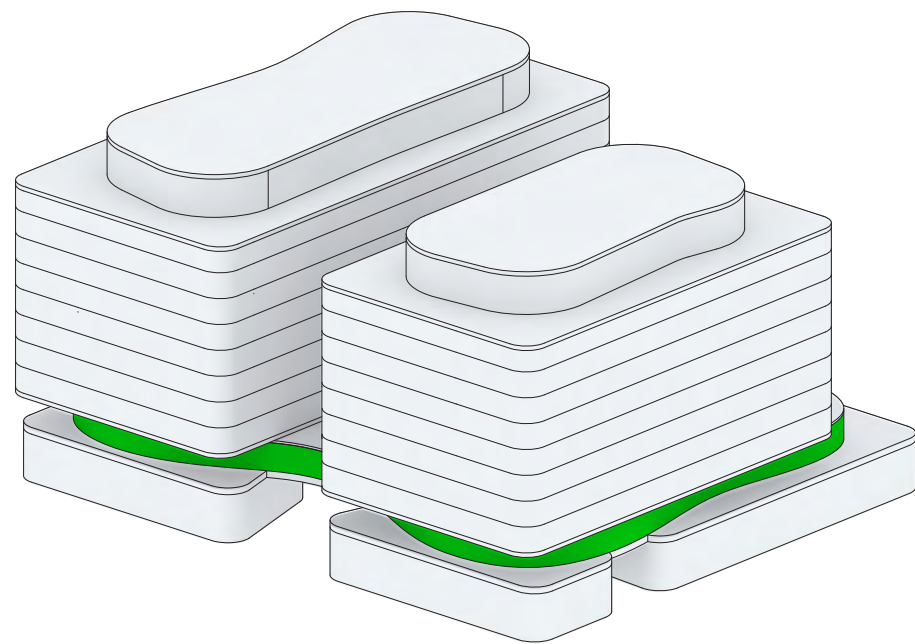

PRECEDENTS

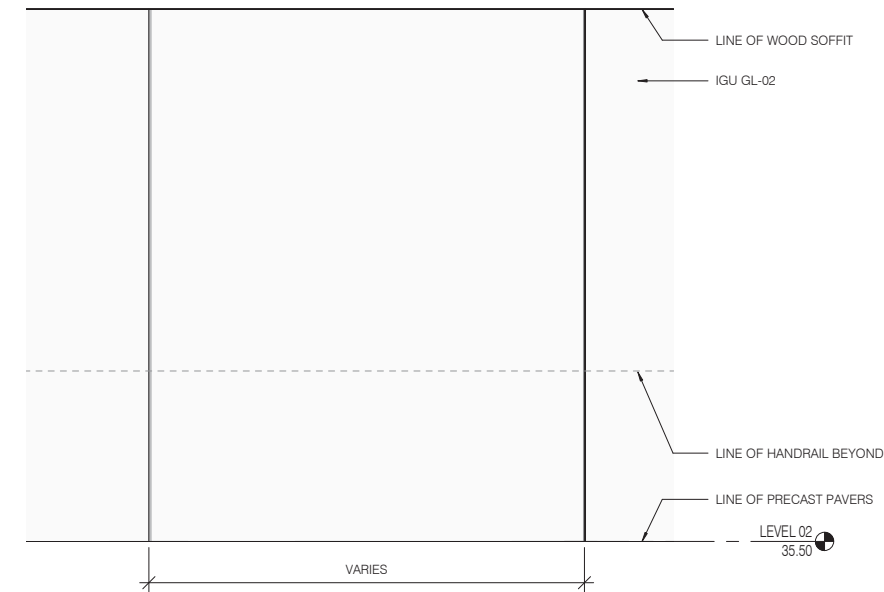

ELEVATION

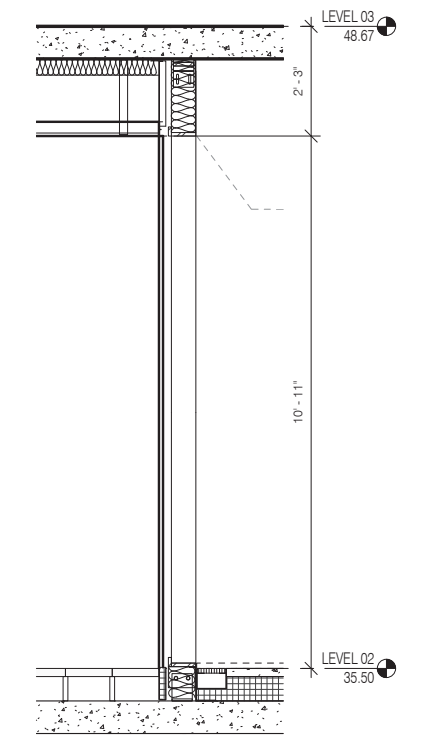

SECTION

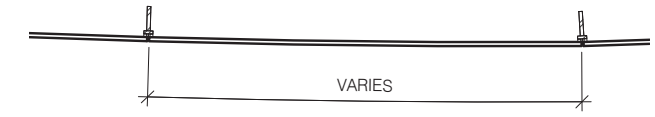

PLAN

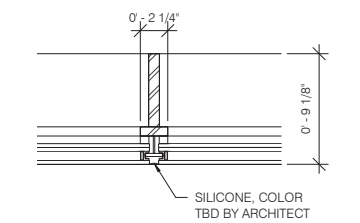

ENLARGED PLAN

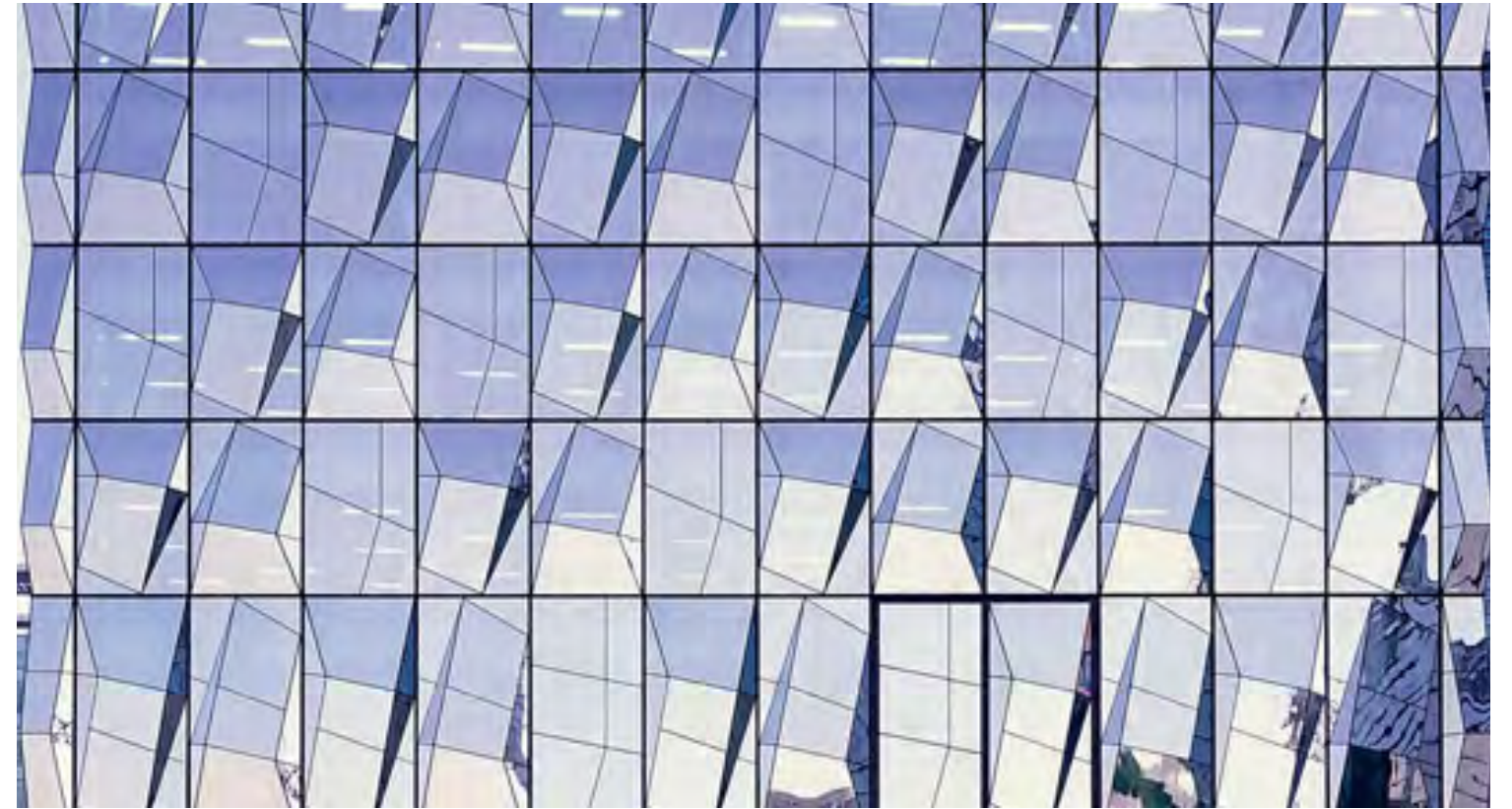
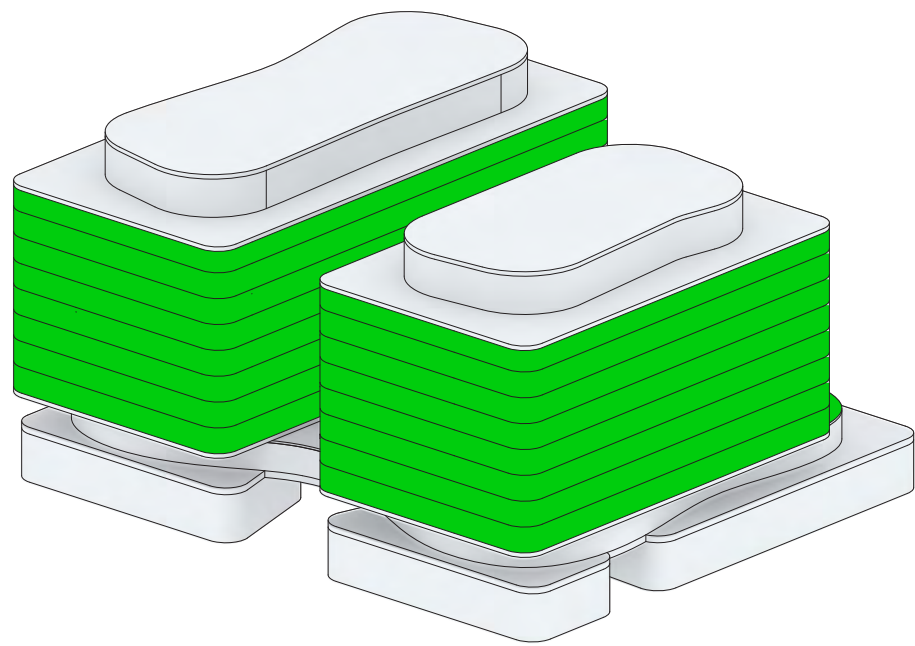

PRECEDENTS

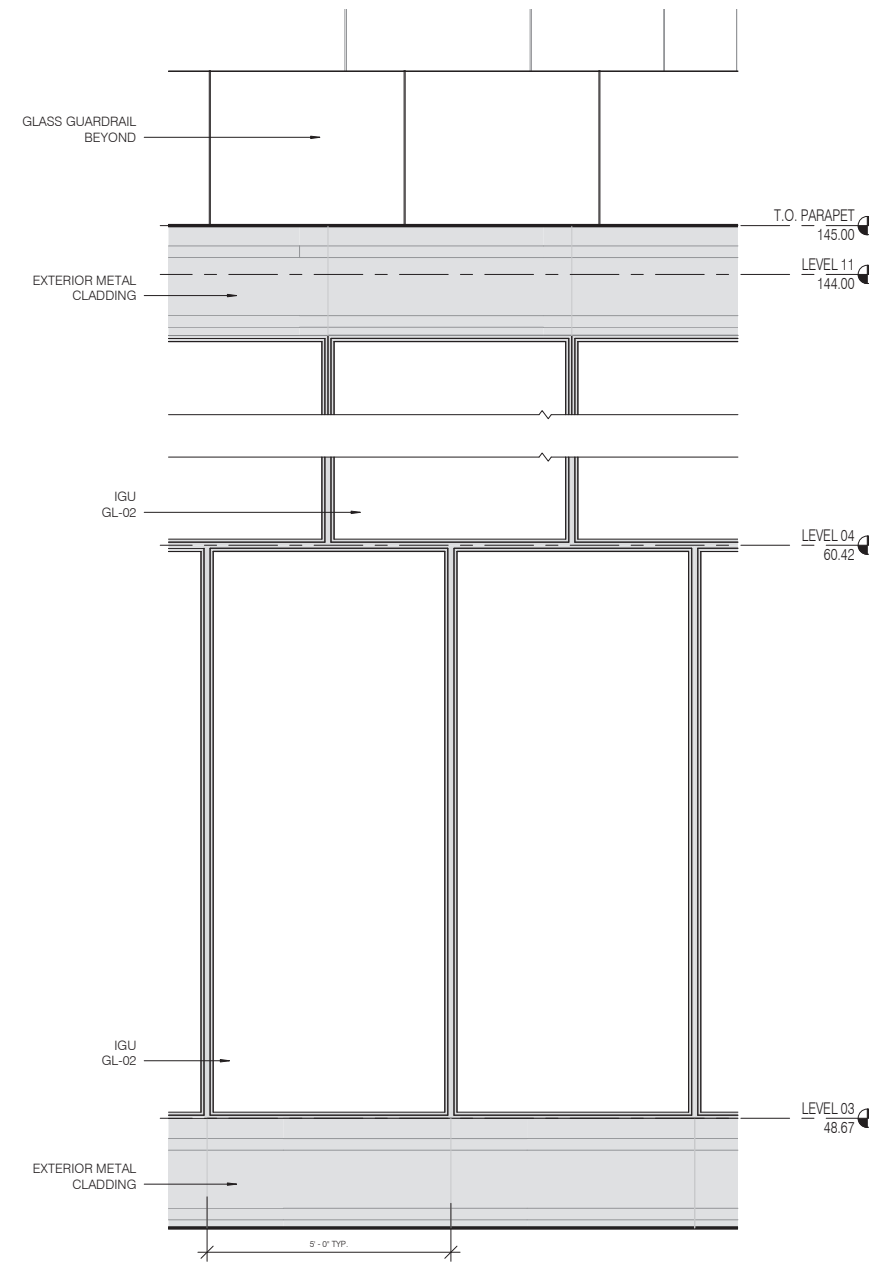
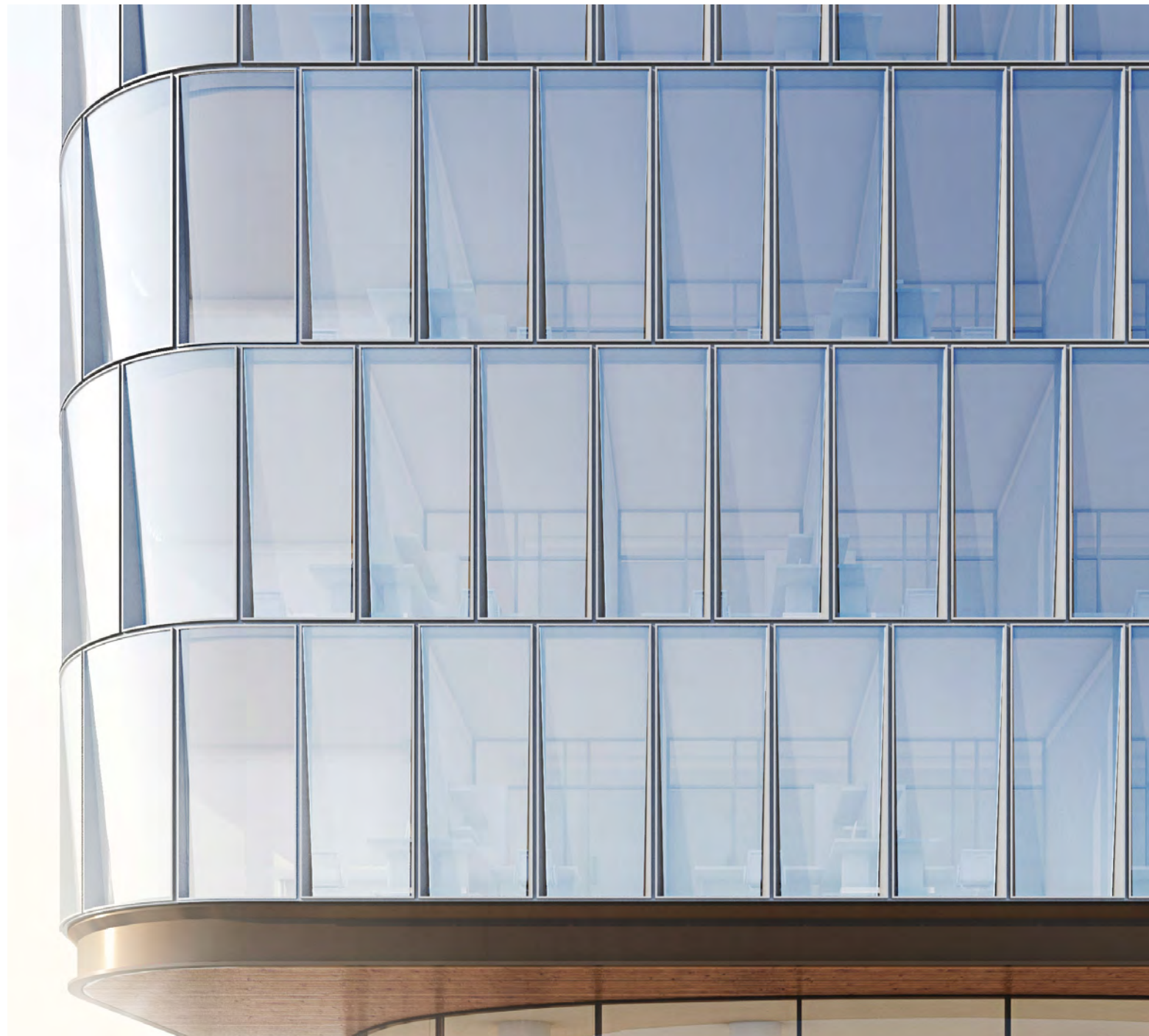

ELEVATION

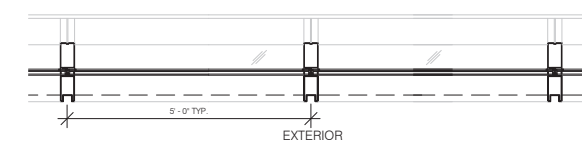

PLAN

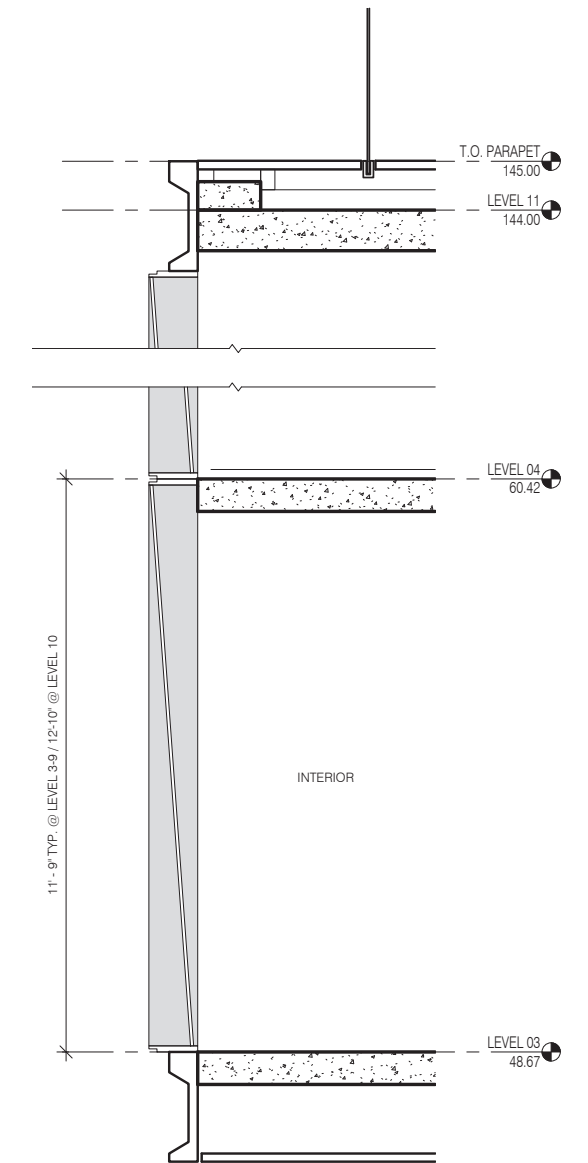

SECTION

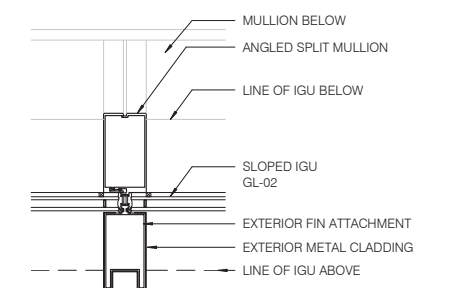

ENLARGED PLAN



LEED for Core & Shell v2009
 The Wharf Phase II: Parcels 6 & 7
 May 9, 2017



25 2 1 Sustainable Sites			Possible Points: 28
Y	?	N	
Y			Prereq 1 Construction Activity Pollution Prevention
1			Credit 1 Site Selection 1
5			Credit 2 Development Density and Community Connectivity 5
	1		Credit 3 Brownfield Redevelopment 1
6			Credit 4.1 Alternative Transportation—Public Transportation Access 6
2			Credit 4.2 Alternative Transportation—Bicycle Storage and Changing Rooms 2
3			Credit 4.3 Alternative Transportation—Low-Emitting and Fuel-Efficient Vehicles 3
2			Credit 4.4 Alternative Transportation—Parking Capacity 2
1			Credit 5.1 Site Development—Protect or Restore Habitat 1
1			Credit 5.2 Site Development—Maximize Open Space 1
	1		Credit 6.1 Stormwater Design—Quantity Control 1
1			Credit 6.2 Stormwater Design—Quality Control 1
1			Credit 7.1 Heat Island Effect—Non-roof 1
1			Credit 7.2 Heat Island Effect—Roof 1
		1	Credit 8 Light Pollution Reduction 1
1			Credit 9 Tenant Design and Construction Guidelines 1

5 3 2 Water Efficiency			Possible Points: 10
Y	?	N	
Y			Prereq 1 Water Use Reduction—20% Reduction
2	2		Credit 1 Water Efficient Landscaping 4
		2	Credit 2 Innovative Wastewater Technologies 2
3	1		Credit 3 Water Use Reduction 4

14 7 16 Energy and Atmosphere			Possible Points: 37
Y	?	N	
Y			Prereq 1 Fundamental Commissioning of Building Energy Systems
Y			Prereq 2 Minimum Energy Performance
Y			Prereq 3 Fundamental Refrigerant Management
6	3	12	Credit 1 Optimize Energy Performance 21
		4	Credit 2 On-Site Renewable Energy 4
2			Credit 3 Enhanced Commissioning 2
	2		Credit 4 Enhanced Refrigerant Management 2
1	2		Credit 5.1 Measurement and Verification - Base Building 3
3			Credit 5.2 Measurement and Verification - Tenant Submetering 3
2			Credit 6 Green Power 2

6 1 6 Materials and Resources			Possible Points: 13
Y	?	N	
Y			Prereq 1 Storage and Collection of Recyclables
		5	Credit 1 Building Reuse—Maintain Existing Walls, Floors, and Roof 5
2			Credit 2 Construction Waste Management 2
		1	Credit 3 Materials Reuse 1
2			Credit 4 Recycled Content 2
2			Credit 5 Regional Materials 2
	1		Credit 6 Certified Wood 1

7 3 2 Indoor Environmental Quality			Possible Points: 12
Y	?	N	
Y			Prereq 1 Minimum Indoor Air Quality Performance
Y			Prereq 2 Environmental Tobacco Smoke (ETS) Control
		1	Credit 1 Outdoor Air Delivery Monitoring 1
	1		Credit 2 Increased Ventilation 1
1			Credit 3 Construction IAQ Management Plan—During Construction 1
1			Credit 4.1 Low-Emitting Materials—Adhesives and Sealants 1
1			Credit 4.2 Low-Emitting Materials—Paints and Coatings 1
1			Credit 4.3 Low-Emitting Materials—Flooring Systems 1
1			Credit 4.4 Low-Emitting Materials—Composite Wood and Agrifiber Products 1
	1		Credit 5 Indoor Chemical and Pollutant Source Control 1
	1		Credit 6 Controllability of Systems—Thermal Comfort 1
1			Credit 7 Thermal Comfort—Design 1
		1	Credit 8.1 Daylight and Views—Daylight 1
1			Credit 8.2 Daylight and Views—Views 1

6 0 0 Innovation and Design Process			Possible Points: 6
Y	?	N	
1			Credit 1.1 Innovation in Design: Exemplary Performance SSc4.1 1
1			Credit 1.2 Innovation in Design: Exemplary Performance SSc7.1 1
1			Credit 1.3 Innovation in Design: Exemplary Performance or Walkable Sites 1
1			Credit 1.4 Innovation in Design: Green Cleaning 1
1			Credit 1.5 Innovation in Design: Integrated Pest Management 1
1			Credit 2 LEED Accredited Professional 1

1 1 2 Regional Priority Credits			Possible Points: 4
Y	?	N	
		1	Credit 1.1 Regional Priority: EAc1 (40%)/ EAc2 (4pts) 1
	1		Credit 1.2 Regional Priority: SSc6.1 1
1			Credit 1.3 Regional Priority: SSc5.1 1
		1	Credit 1.4 Regional Priority: WEc2, EAc2 (1%), MRc1(75%) 1

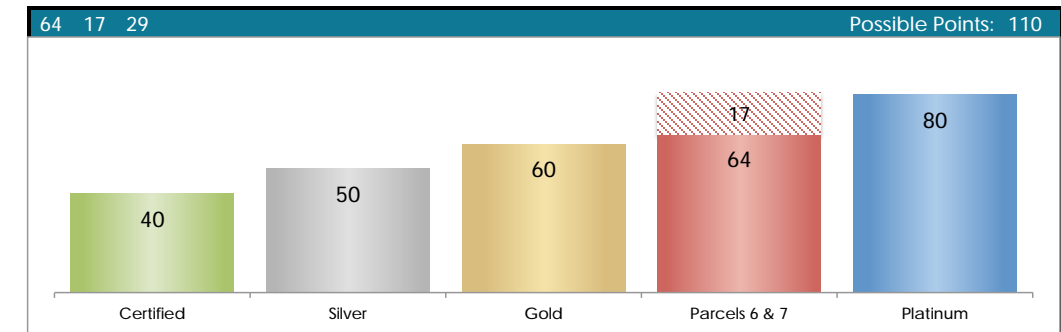

2 FLOORS BASE WITH ROOF TERRACE
34' BUILDING HEIGHT

RETAIL/ RESTURANT
MARITIME SERVICES
TOTAL

11,033 GFA
853 GFA
11,886 GFA



2

WATER BUILDING 1





2.2

WB1: Perspective View from The Wharf
SUPPLEMENTAL PREHEARING SUBMISSION | OCTOBER 13, 2017

DISTRICT
WHARF





01

THE WATER BUILDING 1 DESIGN IS INSPIRED BY THE SURROUNDING CONTEXT OF THE WATERFRONT PROMENADE AT THE WHARF.

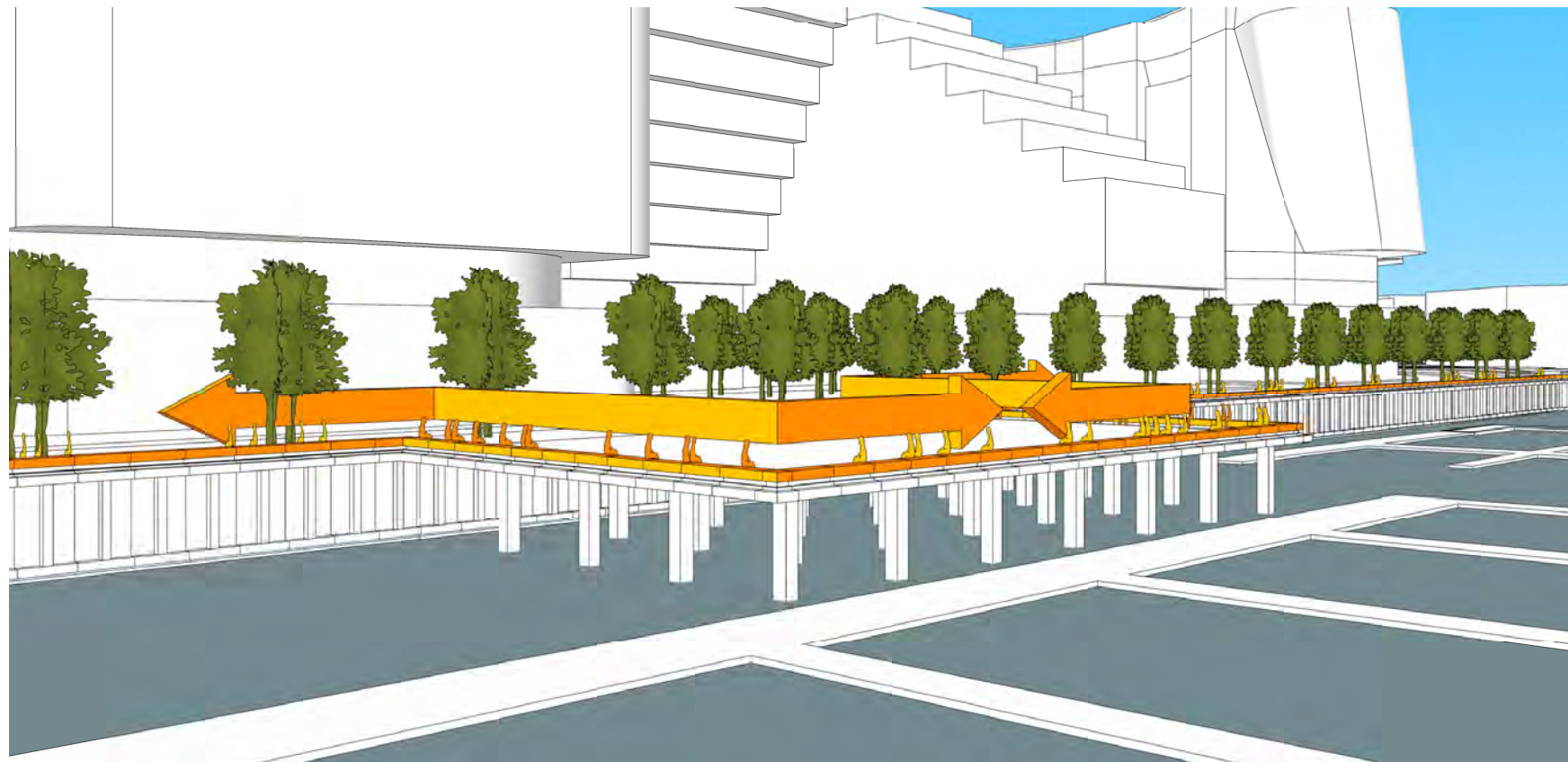

02

THE PIER GROWS OUT OF THE BULKHEAD LINE AT THE WATERFRONT TO FORM THE WB1 PARCEL. THE SITE IS A NATURAL EXTENSION OF THE PROMENADE, UTILIZING SIMILAR URBAN LANDSCAPE ELEMENTS FOR PEDESTRIAN USE.

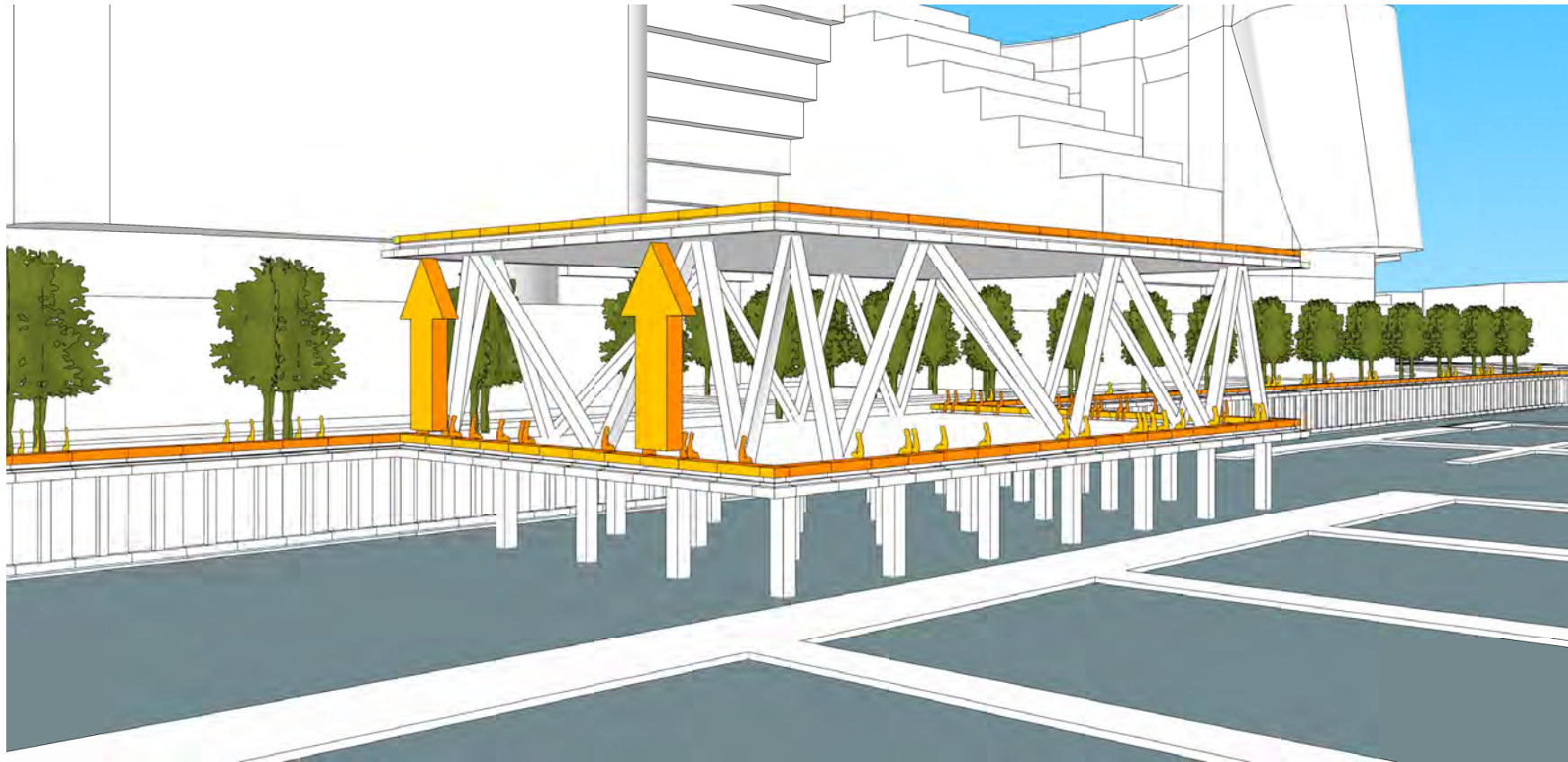

03

THE EXTENDED PIER BAND IS DUPLICATED AND LIFTED TO FORM A UNIQUE COVERED SPACE FOR PROGRAM. A PLAYFUL TRUSS INTRODUCES A DYNAMIC LANGUAGE THAT UNIFIES THESE PIER BANDS. WHILE SUPPORTING THE LANDSCAPED ROOF, THIS TRUSS CREATES AN ICONIC STRUCTURAL ELEMENT, GIVING THE BUILDING PERSONALITY.



04

THE INTERIOR SPACE IS ENCLOSED IN A SIMPLE GLASS FACADE ALLOWING FOR UNOBSTRUCTED VIEWS OF THE WHARF FROM INSIDE, WHILE HEIGHTENING THE ICONIC QUALITIES OF THE STRUCTURAL TRUSS AND BUILDING.